

# HSDB01 Hand Held Soda Blaster

Soda blasting gun- clean or remove without damaging

1. wear protective equipment; respiratory protection, eye protection ,eye protection ,ear protection and gloves during blasting
2. Fill the container with dry soda blasting media .wet or moist soda can clog the device and cause a malfunction.Maximum 3/4 filled.
3. Connect the soda blasting gun to the compressed air line system.
4. Adjust the compressor pressure to the required value.
5. Press the trigger all the way down, and find the right flow of soda by adjusting the nozzle .to find the default setting screw on the nozzle (3)until it stops with the locking ring (4)fully mounted, default setting is 2 1/2 turns / 2 1/2-3mm up from here. the amount of soda should be neither too low nor too high –test it by directing the blast onto some less visible part of the work piece. Once you have got the right flow of soda, lock the nozzle by turning the locking ring.
6. Improve the overall performance by adjusting the pressure, the distance and the amount of soda.
7. When finished clean of soda dust e.g. with a blowgun or by vacuuming .if your work piece is to be painted after the blasting, it is a good idea to clean it thoroughly before painting.

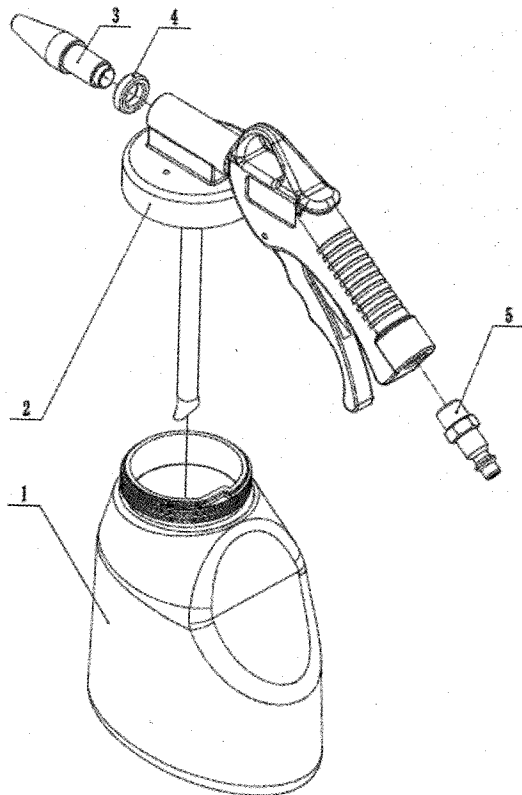

No.	Name	QTY
1	Soda Container	1
2	Soda blasting Gun	1
3	Nozzle	1
4	Lock Ring	1
5	Air Inlet	1